

1U Hinged 19 Wall-Mount Panel Bracket Installation Instructions

Product Diagram

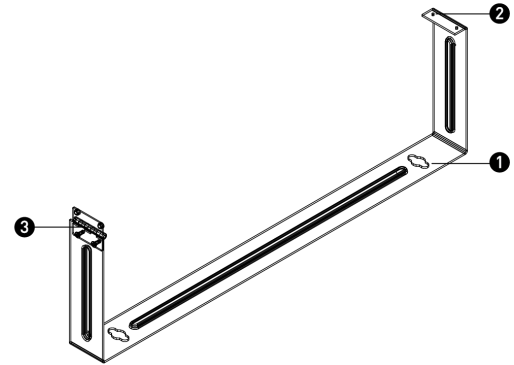
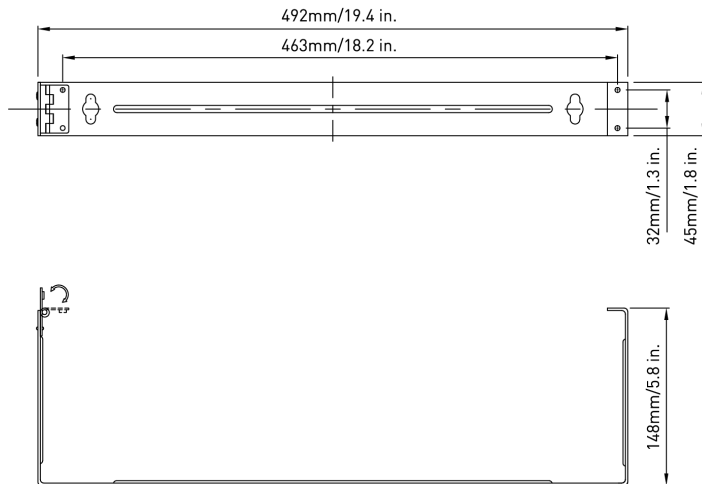

- 1) Wall mounting holes
- 2) Equipment mounting holes
- 3) Access hinge

Important Notes

- The wall mount bracket can support a maximum load of **22 pounds**. Do not overload the wall mount bracket.
- Ensure the wall mount bracket is installed on a level, sturdy wall capable of supporting the weight of the bracket and connected equipment.
- Installation by a professional is recommended.

Installation Instructions

- 1) Using the included screws, attach and secure the bracket to a sturdy wall capable of supporting the weight of the bracket and networking equipment.
- 2) Attach a patch panel and networking equipment (sold separately) to the mount.

Package Contents

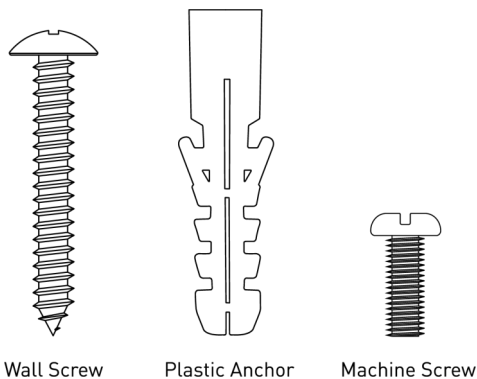

- 1) 1x 1U Hinged 19 Wall-Mount Panel Bracket
- 2) 2x Wall screws
- 3) 2x Plastic anchors
- 4) 4x Machine screws
- 5) 1x Instruction sheet

Warranty and Support Info

Cable Matters offers lifetime technical support as an integral part of our commitment to provide industry leading solutions. Email us with any questions at support@cablematters.com.

Warranty Information

This product is backed by a limited one-year warranty. Cable Matters warrants its products against defects in materials and workmanship for the periods noted, following the initial date of purchase. During this period, the products may be returned for repair or replaced with equivalent products at our discretion. The warranty covers parts and labor costs only. Cable Matters does not warrant its products from defects or damages arising from misuse, abuse, alteration, or normal wear and tear.

Limitation of Liability

In no event shall Cable Matters Inc. (including their officers, directors, employees or agents) be liable for any damages (whether direct or indirect, special, punitive, incidental, consequential, or otherwise), loss of profits, loss of business, or any pecuniary loss, arising out of, or related to the use of this product exceeding the actual price paid for the product. Some states do not allow the exclusion or limitation of incidental or consequential damages. If such laws apply, the limitations or exclusions contained in this statement may not apply to you.

Cable Matters® is a registered trademark or trademark of Cable Matters Inc. All rights reserved. All other trademarks are the property of their respective owners.